



**EUROPEAN NEW CAR ASSESSMENT PROGRAMME
(Euro NCAP)**

**FRONTAL IMPACT
TESTING PROTOCOL**

Version 5.1
June 2011

Copyright ©Euro NCAP - This work is the intellectual property of Euro NCAP. Permission is granted for this material to be shared for non-commercial, educational purposes, provided that this copyright statement appears on the reproduced materials and notice is given that the copying is by permission of Euro NCAP. To disseminate otherwise or to republish requires written permission from Euro NCAP.

Preface

- Where text is contained within square brackets this denotes that the procedure being discussed is currently being trialled in Euro NCAP. Its incorporation in the Test Protocol will be reviewed at a later date.
- During the test preparation, vehicle manufacturers are encouraged to liaise with the laboratory and to check that they are satisfied with the way cars are set up for testing. Where a manufacturer feels that a particular item should be altered, they should ask the laboratory staff to make any necessary changes. Manufacturers are forbidden from making changes to any parameter that will influence the test, such as dummy positioning, vehicle setting, laboratory environment etc.
- It is the responsibility of the test laboratory to ensure that any requested changes satisfy the requirements of Euro NCAP. Where a disagreement exists between the laboratory and manufacturer, the Euro NCAP secretariat should be informed immediately to pass final judgment. Where the laboratory staff suspect that a manufacturer has interfered with any of the set up, the manufacturer's representative should be warned that they are not allowed to do so themselves. They should also be informed that if another incident occurs, they will be asked to leave the test site.
- Where there is a recurrence of the problem, the manufacturer's representative will be told to leave the test site and the Secretary General should be immediately informed. Any such incident may be reported by the Secretary General to the manufacturer and the person concerned may not be allowed to attend further Euro NCAP tests.

In addition to the settings specified in this protocol, the following information will be required from the manufacturer of the car being tested in order to facilitate the vehicle preparation. A vehicle handbook should be provided to the test laboratory prior to preparation.

Manufacturer-Specified Settings	
Adjustment	Section Reference
Frontal Impact	
Fuel Tank Capacity	Manufacturer's Handbook
Unladen Kerb Weight	Manufacturer's Handbook
Tyre Pressures	Manufacturer's Handbook
Seat Back/Torso Angle	
95 th Percentile Male Seating Position	Section 6.1
Seat Base Tilt	Section 6.1
Rear seat position (where applicable)	Manufacturer's Handbook Section 6.4
Child Seat Make/Model	
Door Handle Pull Angle	Section 9.4
50 th Percentile Seat belt anchorage position	Section 6.0
Seat Lumbar Support Position	
Engine Running	
Driver Airbag Removal Instructions	
Pre-crash system disabling instructions	(where applicable)
Side Impact	
As Front, in addition:	
Height of non-adjustable version of front seat	Section 5.2
R-Point	Section 1.4

Contents

Page No.

Frontal Impact

1 VEHICLE PREPARATION	1
1.1 Unladen Kerb Mass	1
1.2 Reference Loads	1
1.4 Vehicle Preparation	2
1.5 Vehicle Markings	3
2 INTRUSION MEASUREMENTS	5
2.1 Before Test	5
2.2 After Test	6
3 DUMMY PREPARATION AND CERTIFICATION	8
3.1 General	8
3.2 Dummy Certification	8
3.3 Additions and Modifications to the Hybrid III Dummies	8
3.4 Dummy Clothing and Footwear	9
3.5 Dummy Test Condition	9
3.6 Post Test Dummy Inspection	10
4 INSTRUMENTATION	11
4.1 Dummy Instrumentation	11
4.2 Vehicle Instrumentation	12
5 CAMERA LOCATIONS	14
6 PASSENGER COMPARTMENT ADJUSTMENTS	16
6.1 Determination of and Setting the Fore/aft, Tilt and Lumbar Settings of the Seat.	17
6.2 Setting the Steering Wheel Horizontal Adjustment	17
6.3 Setting the Steering Wheel Vertical Adjustment	18
6.4 Use of The Gabarit and Marking For Child Dummy Head Excursion Measurement	18
7 DUMMY POSITIONING AND MEASUREMENTS	20
7.1 Determine the H-point of the driver's seat	20
7.2 Determine the H-point of the Passenger's Seat	21
7.3 Dummy Installation	21
7.4 Dummy Placement	22
7.5 Dummy Positioning	22
7.6 Child Restraint System (CRS) Installation and Child Dummy Placement	24
7.7 Dummy Measurements	28
8 STILL PHOTOGRAPHY	29
9 TEST PARAMETERS	31
9.1 Deformable Barrier	31
9.2 Speed	31

9.3 Overlap	31
9.4 Door Opening Force	32
9.5 Dummy Removal	32
9.6 Intrusion Measurements	32
10 CALCULATION OF INJURY PARAMETERS	33
10.1 Head	34
10.2 Neck	35
10.3 Chest	35
10.4 Femurs	35
10.5 Knees	35
10.6 Tibia	35
10.7 Child Dummies	36
Appendix I	37
BARRIER SPECIFICATION	38
1 Component and Material Specifications	38
2 Aluminium Honeycomb Certification	39
3 Adhesive Bonding Procedure	41
4 Construction	42
5 Mounting	42

1 VEHICLE PREPARATION

1.1 Unladen Kerb Mass

- 1.1.1 The capacity of the fuel tank will be specified in the manufacturer's booklet. This volume will be referred to throughout as the "fuel tank capacity".
- 1.1.2 Syphon most of the fuel from the tank and then run the car until it has run out of fuel.
- 1.1.3 Calculate the mass of the fuel tank capacity using a density for petrol of 0.745g/ml or 0.840g/ml for diesel. Record this figure in the test details.
- 1.1.4 Put water, or other ballast, to this mass in the fuel tank.
- 1.1.5 Check the oil level and top up to its maximum level if necessary. Similarly, top up the levels of all other fluids to their maximum levels if necessary.
- 1.1.6 Ensure that the vehicle has its spare wheel on board along with any tools supplied with the vehicle. Nothing else should be in the car.
- 1.1.7 Ensure that all tyres are inflated according to the manufacturer's instructions for half load.
- 1.1.8 Measure the front and rear axle weights and determine the total weight of the vehicle. The total weight is the 'unladen kerb mass' of the vehicle. Record this mass in the test details.
- 1.1.9 Measure and record the ride heights of the vehicle at all four wheels

1.2 Reference Loads

- 1.2.1 Calculate 10 percent of the fuel tank capacity mass as determined in 1.1.3
- 1.2.2 Remove this mass of ballast from the fuel tank, leaving 90 percent of the mass in the tank.
- 1.2.3 Place both front seats in their mid-positions. If there is no notch at this position, set the seat in the nearest notch rearward (this will be done more completely in Section 6).
- 1.2.4 Place a mass of equivalent to a Hybrid-III dummy (88kg with instrumentation and cables) on each of the front seats.
- 1.2.5 Place 36kg in the luggage compartment of the vehicle. The normal luggage compartment should be used i.e. rear seats should not be folded to increase the luggage capacity. Spread the weights as evenly as possible over the base of the luggage compartment. If the weights cannot be evenly distributed, concentrate weights towards the centre of the compartment.
- 1.2.6 In the child restraints recommended by the manufacturer, place masses equivalent to a 3 and a 1½ year old child dummy on the rear driver seat and passenger seats respectively (15kg and 11kg). If the child restraints are not available at this time then default masses of 3kg should be added to the dummy masses.
- 1.2.7 For two seater vehicles only, the mass of child dummies and child seats shall not be included in the reference load. For vehicles with limited rear space, child seats and dummies shall be included in the reference load.
- 1.2.8 Roll the vehicle back and forth to 'settle' the tyres and suspension with the extra weight on board. Weigh the front and rear axle weights of the vehicle. These loads are the "axle reference loads" and the total weight is the "reference mass" of the vehicle.
- 1.2.9 Record the axle reference loads and reference mass in the test details
- 1.2.10 Record the ride-heights of the vehicle at the point on the wheel arch in the same transverse plane as the wheel centres. Do this for all four wheels.
- 1.2.11 Remove the weights from the luggage compartment and the front and rear seats.

1.3 Vehicle Width and Overlap

- 1.3.1 Determine the widest point of the vehicle ignoring the rear-view mirrors, side marker lamps, tyre pressure indicators, direction indicator lamps, position lamps, flexible mud-guards and the deflected part of the tyre side-walls immediately above the point of contact with the ground.
- 1.3.2 Record this width in test details.
- 1.3.3 Determine the centre-line of the vehicle. Calculate 10% of the vehicle width (Section 1.4.6) and mark a line on the bonnet and bumper which is this distance from the centre line on the steering-wheel side of the car. The distance from this line to the widest point on the steering wheel side of the car will be the overlap with the deformable barrier.

Take the pre-impact vehicle intrusion measurements at this point. See Section 2 for a full description of how to do this.

1.4 Vehicle Preparation

Care should be taken during vehicle preparation that the ignition is not switched on with the battery or airbag disconnected. This will result in an airbag warning light coming on and the airbag system will need to be reset. The manufacturer will need to be contacted if this occurs.

- 1.4.1 Ensure that the vehicle's battery is connected to the vehicle's electrical circuit in its standard position. Check that the dashboard light for the airbag circuit functions as normal. Alternatively, the vehicle battery acid may be drained or an additional live battery may be placed in the luggage compartment of the vehicle. If the supply from the drained battery is not supported by an additional battery, the test must be conducted within fifteen minutes after draining the battery. Where any additional battery is used it must be connected directly to the original battery so that the vehicle's original electrical system, cable routing and connections remain unaltered. The power cables connecting both batteries must be positioned on the non-struck side of the car in such a way to minimise the risk of the cable being cut during the impact. The cable used to connect both batteries must have a minimum cross section of 5mm^2 to ensure a minimum voltage drop. The current supplied to the vehicle must be monitored throughout the impact across the original battery. Where an additional battery is to be used the vehicle manufacturer will be required to indicate the minimum voltage/current needed during the test for all systems to operate as intended. The manufacturer will be asked to confirm that the laboratory modifications are suitable for use in the vehicle being tested and will not influence any of the vehicle systems.
- 1.4.2 In the event that the engine fluids are to be drained then drain the coolant, oil, air-conditioning (air conditioning refrigerant should be drained without venting it to the atmosphere) and Power Assisted Steering (PAS) fluids.
- 1.4.3 If the fluids are drained then measure the weights of each of these fluids, excluding the air conditioning fluid, and replace with an equivalent weight of water or other ballast.
- 1.4.4 Remove the luggage area carpeting, spare wheel and any tools or jack from the car. The spare wheel should only be removed if it will not affect the crash performance of the vehicle.
- 1.4.5 An emergency abort braking system may be fitted to the vehicle. This is optional; the test facility may elect to test without an abort system. Where such a system is fitted its inclusion shall not influence the operation or function of any of the foot controls, in particular the brake pedal. The position and the resistance to movement of the pedals shall be the same as prior to fitment of the system. Remove as little as possible of the

interior trim; any mass compensation will be made when all equipment has been fitted.

- 1.4.6 Fit the on-board data acquisition equipment in the boot of the car. Also fit any associated cables, cabling boxes and power sources.
- 1.4.7 Place weights equivalent to a Hybrid-III dummy (88kg) in each of the front seats of the car (with the seats in their mid-positions).
- 1.4.8 In the child restraints recommended by the manufacturer, place masses equivalent to a 3 and a 1½ year old child dummy on the rear driver's seat and passenger seat respectively (15kg and 11kg). If the child restraints are not available at this time then default masses of 3kg should be added to the dummy masses.
- 1.4.9 Weigh the front and rear axle weights of the vehicle. Compare these weights with those determined in Section 1.2.7.
- 1.4.10 If the axle weights differ from those measured in Section 1.2.7 by more than 5% (of the axle reference loads) or by more than 20kg, remove or add items which do not influence the structural crash performance of the vehicle. Similarly, if the total vehicle mass differs by more than 25kg from the reference mass, non-structural items may be removed or added. The levels of ballast in the fuel tank (equivalent in mass to 90% capacity of fuel) may also be adjusted to help achieve the desired axle weights. Any additional mass that is added to the vehicle should be securely and rigidly attached.
- 1.4.11 Repeat Sections 1.5.9 and 1.5.10 until the front and rear axle weights and the total vehicle weight are within the limits set in 1.5.10. Record the final axle weights in the test details.
- 1.4.12 The vehicle manufacturer will be required to inform Euro NCAP and the test laboratory of the presence of any pre-crash systems that must be disabled prior to impact. Disabling information shall be provided to the laboratory prior to impact. It is the responsibility of the vehicle manufacturer to ensure that the disconnection of the system does not influence the performance of any systems that are intended to function during the impact.

1.5 Vehicle Markings

- 1.5.1 Euro NCAP markings will be attached to the exterior of the vehicle in the following locations; upper half of driver's door, upper half of front passenger's door and on the front half of the roof of the vehicle. Refer to figure 1.1 below.
- 1.5.2 Test house logos may be added to the vehicle provided that they do not detract attention from the Euro NCAP markings. Suitable locations for such markings would be the lower half of the rear doors and on the bonnet at the base of the windscreen.

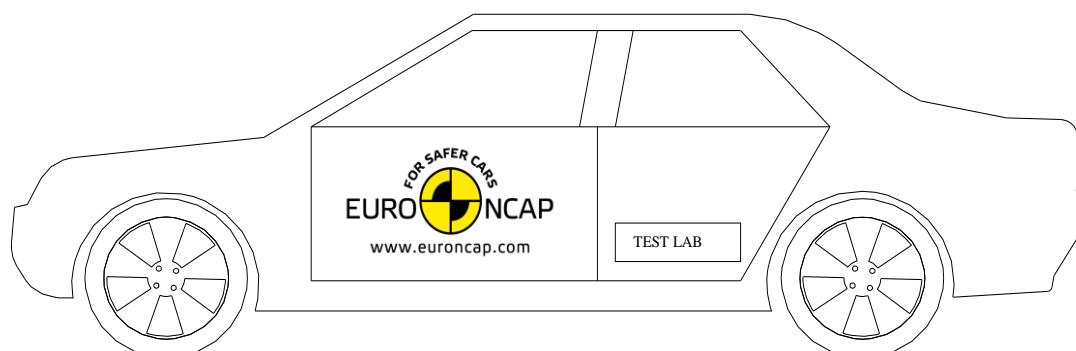

Figure 1.1

2 INTRUSION MEASUREMENTS

For vehicle deformation and intrusion measurements a 3D measuring system which is capable of recording 3 dimensional co-ordinates of a point in space can be used. A tolerance of +/- 1mm is applicable to such a system. The system requires an axis system to be set up relative to the object to be measured, typically the transverse, longitudinal and vertical directions of a vehicle. An origin is first needed, followed by a point on the positive x axis and then a point in the positive x-y plane. Since the front of the vehicle is highly deformed after the impact, it is simplest to use some structure at the rear of the vehicle as a reference for measurement; this obviates the need to level the car after testing, the accuracy of which is limited. Most of the procedure which follows relates to the setting up of these axes.

2.1 Before Test

- 2.1.1 Determine and mark the centre of the clutch, brake and accelerator pedals.
- 2.1.2 Set the steering wheel to its mid-position, if it is adjustable for either rake or reach (for full description of how to do this, see Section 6).
- 2.1.3 Remove the centre of the steering wheel or, if fitted, the airbag assembly to expose the end of the steering column. When doing this, carefully note the connections to the airbag which will need to be remade on re-assembly. Follow the manufacturer's instructions when removing the airbag and/or steering wheel assemblies.
- 2.1.4 Determine and mark the centre of the top of the steering-column.
- 2.1.5 Remove the carpet, trim and spare wheel from the luggage compartment. The plastic trim or rubber seals that might influence the latching mechanism should be re-fitted once the intrusion measurements have been recorded. This is to ensure that any opening of the rear door during the impact is not caused by the omission of some part of the trim around the latching mechanism.
- 2.1.6 Locate the vehicle axis reference frame (see Figure 2.1) centrally to the rear of the vehicle.

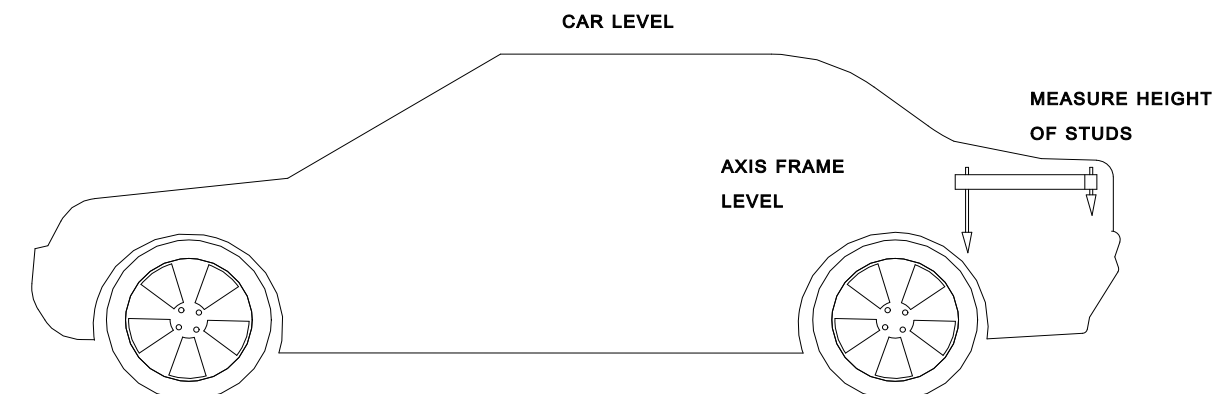

Figure 2.1 Setting up axis reference frame

- 2.1.7 Level the reference frame.
- 2.1.8 Measure and record the stud heights of the reference frame. These will be used after the test to help reset the reference frame, if required.
- 2.1.9 If it is necessary to lean on the vehicle to reach the following points, the vehicle should be supported to maintain the ride heights during measuring.
- 2.1.10 Set up the vehicle co-ordinate axes in the 3D arm or similar device.
- 2.1.11 Mark and record the position of at least 5 datum points on the rear of the vehicle. These points should be on structures which are not expected to be deformed in the

- test and should be positioned such that they have wide spaced locations in three dimensions and can all be reached with the 3D measuring system in one position.
- 2.1.12 Working on the passenger side of the vehicle determine and mark the positions on the B-post which are:
- i) at a distance of 100 mm above the sill.
 - ii) at a distance of 100 mm beneath the lowest level of the side window aperture.
- All points should be as close as possible to the rubber sealing strip around the door aperture.
- 2.1.13 Measure and record the pre-impact positions of the two door aperture points.
- 2.1.14 Working on the driver's side of the vehicle determine and mark the positions on the A and B posts which are:
- i) at a distance of 100 mm above the sill.
 - ii) at a distance of 100 mm beneath the lowest level of the side window aperture.
- All points should be as close as possible to the rubber sealing strip around the door aperture.
- 2.1.15 Use the arm to measure the pre-impact positions of the centre of the top of the steering-column and the four door aperture points.
- 2.1.16 Record the position of the centre of the un-depressed clutch, brake and accelerator pedals and where applicable foot operated parking brake. If the pedal is adjustable, set it to the mid position or a reasonable variation from this in accordance with the manufacturer's recommendations for the 50th percentile position.
- 2.1.17 Replace the steering wheel and airbag assembly. Check that all bolts are securely fastened. Ensure that all connections to the airbag are replaced and check the dashboard light to confirm the circuit is functional.

2.2 After Test

- 2.2.1 Before dummy removal measure the distance between all foot pedals and a fixed point in the footwell e.g. seat runner, seat mounting bolt. If access cannot be gained remove the dummies, according to Section 9.6, taking care not to disturb any pedals and then record the measurement. This measurement should be re-checked before the pedals are measured with the 3D measuring system. If the pedal has moved re-position the pedal using the measurement taken previously.
- 2.2.2 Remove the dummies according to Section 9.6 and remove the data acquisition and emergency abort equipment (if fitted) from the luggage compartment.
- 2.2.3 Remove the centre of the steering wheel or airbag assembly.
- 2.2.4 Use any 3 of the 5 datum points at the rear of the vehicle, and their pre-impact measurements, to redefine the measurement axes.
- 2.2.5 If the axes cannot be redefined from any 3 of the datum points relocate the axis reference frame in the same position as in Section 2.1.8. Set the studs of the frame to the same heights as in Section 2.1.11 (Figure 2.2). The frame should now be in the same position relative to the car as it was before impact. Set up the measurement axes from the frame.
- 2.2.6 Record the post-impact positions of the B-post points on the unstruck passenger's side of the vehicle.
- 2.2.7 Compare the vertical co-ordinate of the B-post sill point before (Section 2.1.12) and after (Section 2.2.5) the test.
- 2.2.8 Find the angle θ that best satisfies the following equation: $z = -x'\sin\theta + z'\cos\theta$ for the B-post sill point (where z = pre impact vertical measurement and x',z' = post-impact

longitudinal and vertical).

- 2.2.9 Working on the struck side of the vehicle, record the post-impact co-ordinates of the centre of the steering column, the centre of the clutch, brake and accelerator pedals, and where applicable a foot operated parking brake, with no load applied to them and in the blocked position (loaded with 200N to produce the maximum moment about the pedal pivot), the door aperture points. Prior to the 'blocked' pedal measurement, i.e. with the 200N applied, the brake fluid shall be removed to avoid the build up of hydraulic pressure. If the steering column has become detached during impact due to the operation of the shear capsules, the column should be repositioned before measurement in the upward and lateral directions so that it is in contact with whatever structure(s) last constrained it from further movement. If any of the foot pedals become detached do not take a measurement of that pedal.
- 2.2.10 Transform the post impact longitudinal and vertical measurements (x',z') using the following equations.

$$\begin{bmatrix} X' \\ Z' \end{bmatrix} = \begin{bmatrix} \cos \theta & \sin \theta \\ -\sin \theta & \cos \theta \end{bmatrix} \begin{bmatrix} x' \\ z' \end{bmatrix}$$

- 2.2.11 Where θ is the angle determined in Section 2.2.8. X and Z should now be in the same frame of reference as the pre-impact measurements.¹
- 2.2.12 From the pre-impact and adjusted post-impact data collected, determine
- the longitudinal, lateral and vertical movement of the centre of the top of the steering column
 - the longitudinal and vertical movement of all of the foot operated pedals
 - the rearward movement of the A-post at waist level
 - the reduction in width of the door aperture at waist and sill levels
- 2.2.13 Record these intrusion measurements in the test details.

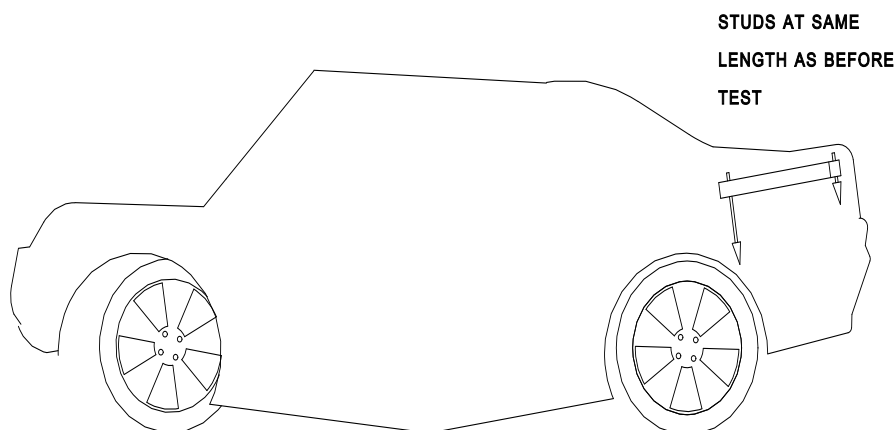

Figure 2.2 Re-setting axis reference frame after test

¹ This assumes that the point on the un-struck B-post sill is not displaced vertically or laterally during the impact.

3 DUMMY PREPARATION AND CERTIFICATION

3.1 General

- 3.1.1 Hybrid III test dummies should be used for the front seat driver and passenger positions. They should conform to U.S. Department of transportation, Code of Federal Regulations Part 572 Subpart E and ECE Regulation No. 94, except for modifications and additions stated later - See Section 3.3.
- 3.1.2 A TNO/Ogle P1½ child dummy, in a suitable Child Restraint System (CRS) (see Section 7.6), shall be used in the rear passenger side seating position.
- 3.1.3 A TNO P3 child dummy, in a suitable CRS (see Section 7.6), shall be used in the rear driver's side seating position.

3.2 Dummy Certification

Full details of the certification procedure for the Hybrid-III dummy are available elsewhere (see Part 572 Subpart E of US Department of Transportation Code of Federal Regulations), SAE Engineering Aid 23 and Annex 10 of ECE Regulation No. 94). Details of the certification procedure of the TNO P1½ and P3 child dummies are available in the user documentation. No manufacturer shall have access to any pre-test information regarding any of the test equipment to be used by Euro NCAP, or be permitted to influence its selection in any way.

- 3.2.1 The Hybrid-III dummies shall be re-certified after every THREE impact tests.
- 3.2.2 The chest shall be certified according to the frequency above and should meet both the low speed thorax test as prescribed by SAE J2779, as well as the full certification test detailed in CFR572. Additionally, chest potentiometer calibration and polynomial post processing shall also be performed as detailed in SAE J2517. See Technical Bulletin 005 for more details.
- 3.2.3 The knee slider shall be certified to SAE J2867 after every THREE impact tests and as specified in SAE EA23 after every NINE impact tests. See Technical Bulletin 006 for more details.
- 3.2.4 The TNO P1½ and P3 child dummies shall be re-certified after every SIX impact tests (e.g. 3 frontal and 3 side impacts, or any combination of the two test types).
- 3.2.5 If an injury criterion reaches or exceeds its normally accepted limit (eg HIC of 1000) then that part of the dummy shall be re-certified.
- 3.2.6 If any part of a dummy is broken in a test then the part shall be replaced with a fully certified component.
- 3.2.7 Copies of the dummy certification certificates will be provided as part of the full report for a test.

3.3 Additions and Modifications to the Hybrid III Dummies

- 3.3.1 The additions and modifications which will change the dynamic behaviour of the test dummies from Part 572E specification dummies are:
 - 3.3.1.1 Ford 45 degree dorsiflexion ankles/feet with rubber bump stops and padded heels are fitted.
 - 3.3.1.2 Roller ball-bearing knees, such as those supplied by ASTC, shall be fitted.
- 3.3.2 Extra instrumentation is also fitted such as enhanced instrumented lower legs and a 6-axis neck. See Section 4 for a full instrumentation list.
- 3.3.3 Foam neck shields, such as those supplied by ASTC, must be fitted to the driver and passenger if a frontal protection airbag is present.

3.4 Dummy Clothing and Footwear

3.4.1 Hybrid-III dummies

3.4.1.1 Each dummy will be clothed with formfitting cotton stretch garments with short sleeves and pants which should not cover the dummy's knees.

3.4.1.2 Each dummy shall be fitted with shoes equivalent to those specified in MIL-S13192 rev P. (size XW)

3.4.2 Child Dummies

3.4.2.1 Each child dummy shall be fitted with close-fitting stretch clothing suitable for an infant of an appropriate age.

3.5 Dummy Test Condition

3.5.1 Dummy Temperature

3.5.1.1 The dummy shall have a stabilised temperature in the range of 19°C to 22°C.

3.5.1.2 A stabilised temperature shall be obtained by soaking the dummy in temperatures that are within the range specified above for at least 5 hours prior to the test.

3.5.1.3 Measure the temperature of the dummy using a recording electronic thermometer placed inside the dummy's flesh. The temperature should be recorded at intervals not exceeding 10 minutes.

3.5.1.4 A printout of the temperature readings is to be supplied as part of the standard output of the test.

3.5.2 Dummy Joints

All constant friction joints should have their 'stiffness' set by the following method

3.5.2.1 Stabilise the dummy temperature by soaking in the required temperature range for at least 5 hours.

3.5.2.2 The tensioning screw or bolt which acts on the constant friction surfaces should be adjusted until the joint can just hold the adjoining limb in the horizontal. When a small downward force is applied and then removed, the limb should continue to fall.

3.5.2.3 The dummy joint stiffnesses should be set as close as possible to the time of the test and, in any case, not more than 24 hours before the test.

3.5.2.4 Maintain the dummy temperature within the range 19° to 22°C between the time of setting the limbs and up to a maximum of 10 minutes before the time of the test.

3.5.3 Dummy face painting

3.5.3.1 With the exception of the Hybrid-III face, the dummies should have masking tape placed on the areas to be painted using the size table below. The tape should be completely covered with the following coloured paints. The paint should be applied close to the time of the test to ensure that the paint will still be wet on impact.

Hybrid-IIIs

Eyebrows (left and right)	Red
Nose	Green
Chin	Yellow
Left Knee	Red
Right Knee	Green
Left Tibia (top to bottom)	Blue, Green, Red, Yellow
Right Tibia (top to bottom)	Yellow, Red, Green, Blue

Child dummies

Top of Head	Blue
-------------	------

Head-band (colours from left to right)

Red, Yellow, Green

NOTE: The tape should be completely covered with the coloured paints specified.

Paint Area Sizes:

Hybrid-IIIs

Eyebrows = $(25/2) \times 50\text{mm}$

Nose = 25 x 40mm strip, down nose centre line

Chin = 25 x 25mm square, centre line of chin

Knees = 50 x 50mm square, knee centre line with bottom edge level with top of tibia flesh

Tibias = 25mm x 50mm, 4 adjacent areas down leg centre line with top edge level with top of tibia flesh

Child Dummies

Top of Head = 50 x 50mm square

Headbands = 25mm wide, widest circumference remaining at eyebrow level at front, extending to the head C of G at each side.

3.6 Post Test Dummy Inspection

3.6.1 The dummies should be visually inspected immediately after the test. Any lacerations of the skin or breakages of a dummy should be noted in the test specification. A dummy may have to be re-certified in this case. Refer to Section 3.2.

4 INSTRUMENTATION

All instrumentation shall be calibrated before the test programme. The Channel Amplitude Class (CAC) for each transducer shall be chosen to cover the Minimum Amplitude listed in the table. In order to retain sensitivity, CACs which are orders of magnitude greater than the Minimum Amplitude should not be used. A transducer shall be re-calibrated if it reaches its CAC during any test. All instrumentation shall be re-calibrated after one year, regardless of the number of tests for which it has been used. A list of instrumentation along with calibration dates should be supplied as part of the standard results of the test. The transducers are mounted according to procedures laid out in SAE J211 (1995). The sign convention used for configuring the transducers is stated in SAE J211.

4.1 Dummy Instrumentation

The dummies to be used shall be instrumented to record the channels listed below.

Hybrid-III

Location	Parameter	Minimum Amplitude	Driver No of channels	Passenger No of channels
Head	Accelerations, $A_x A_y A_z$	250g	3	3
Neck	Forces	$F_x F_y$	9kN	2
		F_z	14kN	1
	Moments, $M_x M_y M_z$	290Nm	3	3
Chest	Accelerations, $A_x A_y A_z$	150g	3	3
	Deflection, D_{chest}	100mm	1	1
Pelvis	Accelerations, $A_x A_y A_z$	150g	3	3
Femurs (L & R)	Forces, F_z	20kN	2	2
Knees (L & R)	Displacements, D_{knee}	19mm	2	2
Upper Tibia (L & R)	Forces, $F_x F_z$	12kN	4	4
	Moments, $M_x M_y$	400Nm	4	4
Lower Tibia ² (L & R)	Forces, $F_x F_z (F_y)$	12kN	4	4
	Moments, $M_x M_y$	400Nm	4	4
Total Channels per Dummy			36	36
Total Channels			72	

² Note that for both dummies the measurement of F_y is at the laboratory's discretion.

TNO P3

Location	Parameter	Minimum Amplitude	No of channels
Head	Accelerations, $A_x A_y A_z$	150g	3
Chest	Accelerations, $A_x A_y A_z$	150g	3
	Total Channels per Dummy		6

TNO P1^{1/2}

Location	Parameter	Minimum Amplitude	No of Channels	
Head	Accelerations, $A_x A_y A_z$	150g	3	
Neck	Forces	$F_x F_y$	1kN	2
		F_z	2kN	1
Chest	Accelerations, $A_x A_y A_z$	150g	3	
	Total Channels per Dummy		9	

4.2 Vehicle Instrumentation

- 4.2.1 The vehicle is to be fitted with an accelerometer on each B-post. The accelerometers are to be fitted in the fore/aft direction (A_x)
- 4.2.2 Remove carpet and the necessary interior trim to gain access to the sill directly below the B-post.
- 4.2.3 Securely attach a mounting plate for the accelerometer horizontally on to the sill, without adversely affecting seat belt retractors and/or pretensioners.
- 4.2.4 Fix the accelerometer to the mounting plate. Ensure the accelerometer is horizontal to a tolerance of ± 1 degree and parallel to the X-axis of the vehicle.
- 4.2.5 Attach lightweight (<100g) seatbelt loadcells to the shoulder section of the driver and passenger seatbelts.

VEHICLE

Location	Parameter	Minimum Amplitude	No of channels
B-Post LHS	Accelerations, A_x	150g	1
B-Post RHS	Accelerations, A_x	150g	1
Driver Seatbelt Shoulder Section	Force, $F_{diagonal}$	16kN	1
Passenger Seatbelt Shoulder Section	Force, $F_{diagonal}$	16kN	1
	Total Channels per Vehicle		4

TOTAL CHANNELS

1× Driver Hybrid-III	36
1× Passenger Hybrid-III	36
1× TNO P3	6
1× TNO P1½	9
1× Vehicle	4
Total Channels per Test	91

5 CAMERA LOCATIONS

Set up high speed film cameras according to the following diagrams

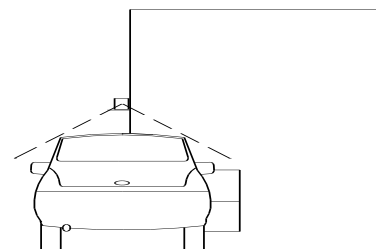
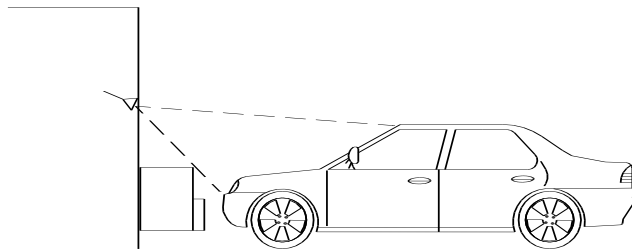
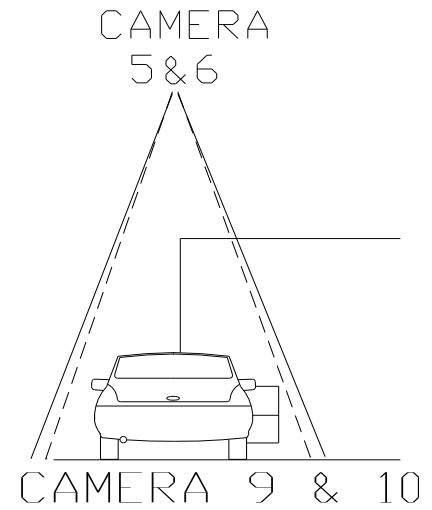
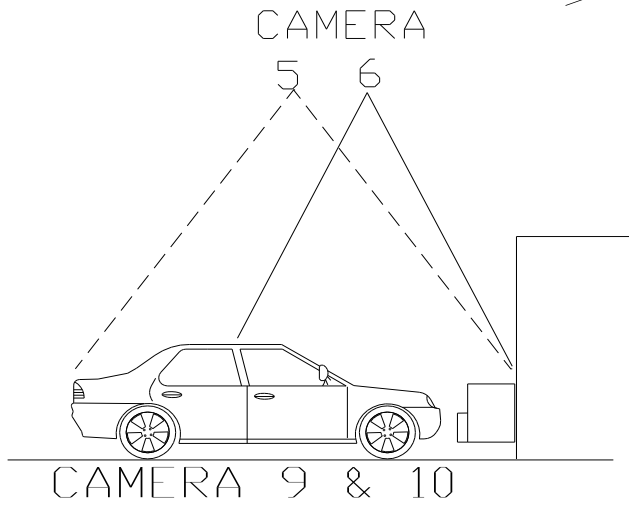
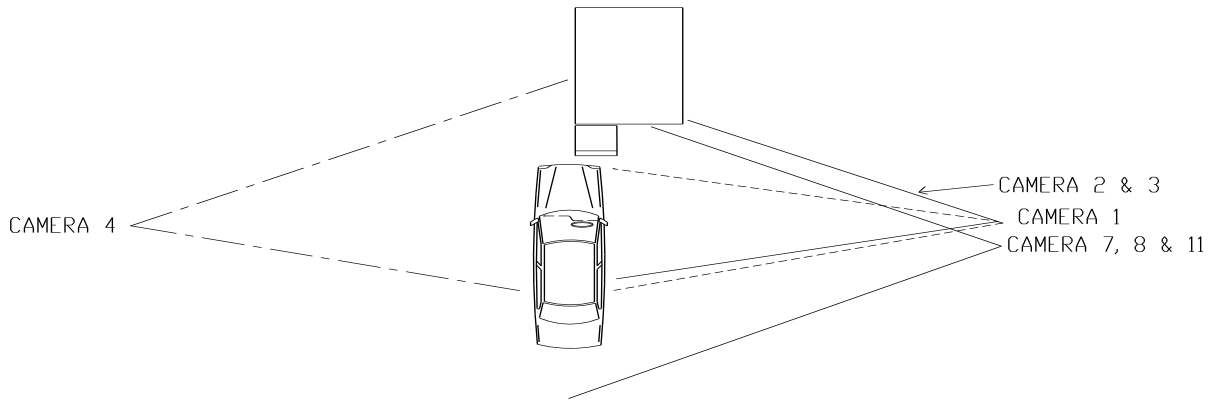

Camera No.	Camera Type	Shot Content
1	>= 500 fps high speed	Driver (tight)
2	>= 500 fps high speed	Driver (wide)
3	>= 500 fps high speed	Backup for 2 (optional)
4	>= 500 fps high speed	Passenger (wide)
5	>= 500 fps high speed	Plan view (wide)
6	>= 500 fps high speed	Plan view (tight)
7	>= 500 fps stills camera	Driver (wide)
8	>= 500 fps stills camera	Backup for 7 (optional)
9	>= 500 fps high speed	Front view driver & passenger
10	>= 500 fps high speed	Backup for 9 (optional)
11	>= 500 fps high speed	Driver (wide)
12	>= 500 fps high speed	Child dummy max head excursion/head protection Onboard
13	>= 500 fps high speed	Child dummy max head excursion/head protection Onboard

- 5.1 The Euro NCAP High Speed Digital Film Specifications are contained in a separate document.
- 5.2 Lens sizes should be chosen appropriately in order to achieve the required shot content/intention. In order to prevent view distortion, a minimum lens size of 9mm is applicable.
- 5.3 Cameras 2, 7 and 9 are considered an essential requirement for all tests for media coverage.
- 5.4 For forward facing CRS, cameras 12 and 13 shall be fitted on the 550mm excursion line and point across the vehicle to capture head excursion. For rearward facing CRS, the camera should capture the head protection/containment, there is no need position the camera on the excursion line.
- 5.5 When attaching onboard cameras, the vehicle manufacturer should be consulted to ensure that no damage is caused to the vehicle that would influence the impact performance. Additionally, the test laboratory should be informed if the side curtain airbags are expected to deploy during the impact. Where additional equipment is added, the mass shall be offset when achieving the final test weight.

6 PASSENGER COMPARTMENT ADJUSTMENTS

Adjustment	Required Setting	Notes	Methods
Seat Fore/Aft	Mid position as defined in Section 6.1	May be set to first notch rearwards of mid position if not lockable at mid position	See Section 6.1
Seat Base Tilt	Manufacturer's design position	Permissible up to Mid Position	See Section 6.1.11
Seat Height	Lowest position		
Seat Back Angle (as defined by torso angle)	Manufacturer's design position	Otherwise 25° to vertical As defined by Torso angle	See Section 7.1.1
Front Head Restraints	Highest position		
Head Restraint Tilt	Manufacturer's design Position	Otherwise mid position	
Seat Lumbar Support	Manufacturer's design position	Otherwise fully retracted	See Section 6.1.12
Steering wheel - vertical	Mid position		See Section 6.3
Steering wheel - horizontal	Mid position		See Section 6.2
Rear Head Restraints	Remove or Lowest	Unless instructed otherwise by the manufacturer	
Rear Seat Fore/Aft	Mid position	Vehicle manufacturer to supply details of seat position contained in handbook when no handbook is available at the time of test.	See Section 6.4.1
Rear Seat Facing	Forwards		See Section 6.4.1
Arm-rests (Front seats)	Lowered position	May be left up if dummy positioning does not allow lowering	
Arm-rests (Rear seats)	Stowed position		
Glazing	Front - Lowered Rear - Lowered or Removed	This applies to opening windows only	
Gear change lever	In the neutral position		
Pedals	Normal position of rest		
Doors	Closed, not locked		
Roof	Lowered	Where applicable	
Sun Visors	Stowed position		
Rear view mirror	Normal position of use		

Seat belt anchorage (where adjustable)	Initially, manufacturer's 50th percentile design position	If no design position then set to mid-position, or nearest notch upwards	
--	---	--	--

Adjustments not listed will be set to mid-positions or nearest positions rearward, lower or outboard.

6.1 Determination of and Setting the Fore/aft, Tilt and Lumbar Settings of the Seat.

- 6.1.1 The manufacturer's seat fore/aft position which corresponds to the 95th percentile male seating position will have been provided.
- 6.1.2 Place a mark on the moving part of seat runner close to the unmoving seat guide.
- 6.1.3 Move the seat to its most forward position of travel.
- 6.1.4 Mark the unmoving seat guide in line with the mark on the seat runner. This corresponds to the seat in its most forward position.
- 6.1.5 Move the seat to the position of its travel provided for the 95th percentile male.
- 6.1.6 Mark the unmoving seat guide in line with the mark on the seat runner. This corresponds to the 95th percentile male's seating position.
- 6.1.7 Measure the distance between the forwards and rearwards marks. Place a third mark on the seat guide mid-way between the forwards and rearwards marks.
- 6.1.8 Move the seat so that the mark on the seat runner aligns with the mark on the seat guide.
- 6.1.9 Lock the seat at this position. Ensure that the seat is fully latched in its runners on both sides of the seat. The seat is now defined as being at its 'mid seating position'. The vehicle will be tested with the seat in this position.
- 6.1.10 If the seat will not lock in this position, move the seat to the first locking position that is rear of the mid seating position. The vehicle will be tested with the seat in this position.
- 6.1.11 If the seat base is adjustable for tilt it may be set to any angle from the flattest up to its mid position according to the manufacturer's preference. The same seat tilt setting must be used for frontal and side impact.
- 6.1.12 If the seat back is adjustable for lumbar support it should be set to the fully retracted position, unless the manufacturer specifies otherwise or the dummy prevents this.

6.2 Setting the Steering Wheel Horizontal Adjustment

- 6.2.1 Choose a part of the fascia that is adjacent to the steering column and can be used as a reference.
- 6.2.2 Move the steering wheel to the most forward position of its travel
- 6.2.3 Mark the steering column in line with an unmoving part of the fascia. This corresponds to the most forward travel of the steering wheel.
- 6.2.4 Move the steering wheel to the most rearwards position of its travel
- 6.2.5 Mark the steering column in line with an unmoving part of the fascia. This corresponds to the most rearwards travel of the steering wheel.
- 6.2.6 Measure the distance between the forwards and rearwards marks on the steering column. Place a third mark on the steering column mid-way between the forwards and rearwards marks. This corresponds to the centre of travel of the steering wheel.
- 6.2.7 Move the steering wheel so that the mark on the steering column aligns with the fascia.
- 6.2.8 Lock the steering column at this position. The steering wheel is now in its mid-position of travel. The vehicle will be tested with the steering wheel in this position.

6.3 Setting the Steering Wheel Vertical Adjustment

A method that is in principle the same as Section 6.2 should be used to determine and set the steering wheel vertical adjustment to the mid position.

It is unlikely that the same part of the fascia used during the setting procedures for the horizontal adjustments could be used for the vertical adjustment.

Care should be taken to avoid unintentional adjustment of the horizontal setting during the vertical adjustment procedure.

6.4 Use of The Gabarit and Marking For Child Dummy Head Excursion Measurement

A device known as a Gabarit (as defined in ECE Regulation 16) is used to check the compatibility of the vehicle with ECE Regulation 44.03 Universal child restraints. This device is used to check the following;

- i) the position of the buckle tongue stop on the adult seat belt to ensure compatibility with all types of child restraint.
- ii) the length of the adult seat belt webbing compared to the requirement of Universal restraints for those seats designated as suitable for such restraints.
- iii) and the position of the adult seat belt hardware relative to the belt contact zones specified for universal child restraints.

Position the Gabarit in all seating positions within the vehicle, excluding the driver's, as specified in ECE Regulation 16. Photographs of the installation, and in particular, the position of the lap section of the belt (both sides) and buckle tongue slot in relation to the 150mm radius shall be taken. The position of the base of the Gabarit relative to the front of the car seat base cushion should also be photographed for each seating position examined. The photograph should be taken from a point in a horizontal plane passing through the top of the car seat base cushion, to illustrate if there is an air gap between the gabarit base and car seat base cushion and any other indication of insufficient belt webbing.

The test laboratory shall specify in the test report whether the three point seat belts fitted to the vehicle are in accordance with ECE Regulation 16, Section 8.2.2.5.

This assessment will be done in accordance with ECE Regulation 16 Annex 13. The vehicle handbook will be checked for guidance about which seat positions in the vehicle are suitable for use with Universal child restraints and which seat positions are unsuitable for use by children. In addition the Cr point within the vehicle will be defined by use of the Gabarit.

- 6.4.1 If the vehicle rear seat position is adjustable put it in the mid position of its horizontal adjustment range, unless the manufacturer's handbook says otherwise when using child seats, and adjust the seat back angle in accordance with the procedure in 7.1. If the direction of facing of the seat is adjustable it should be set to face forward, with its axis parallel to the fore/aft direction of the vehicle.
- 6.4.2 If the adult seat belt has an adjustable upper anchorage set the anchorage in the lowest position unless permanently attached instructions on the child restraint or vehicle suggest otherwise.
- 6.4.3 With the Gabarit positioned as specified in ECE Regulation 16, the positions of the back and bottom planes of the device will be defined using the 3D Measuring arm, targets will be applied to the top and side surfaces of the Gabarit to help in this process. The intersection of these planes will define the Cr point for the seating position in question. The Cr point is needed to give a reference point for head excursion measurement on the dummy.

- 6.4.4 The vehicle should be clearly marked to define a scale of at least 400-600mm (50mm increments) forward of the Cr point. The intention is that these marks should be clearly visible on the high speed film. The camera views should be set to try to minimise parallax error when viewing the dummy head at full excursion relative to the defined scales. Marking should be applied to the exterior top and waist level of the door as well as inside the car at waist level. Having noted the scale points that are aligned at full excursion from the high speed film, the same points will be identified on the car statically after test. The points will be joined by a straight line and the dummy forward excursion deduced by considering the forward excursion indicated at the mid line of the seating position in question.
- 6.4.5 The 550mm excursion line shall be clearly distinguished from the other markings in some way, for example using a different colour. This line shall also be marked on the vehicle in locations that are clearly visible to the onboard cameras. Alternatively, it is acceptable for the line across the vehicle to be superimposed during post film processing.

7 DUMMY POSITIONING AND MEASUREMENTS

The following chapter deals with all aspects of seating the dummy in the vehicle to be tested. A general timetable of the complete procedure is set out below:-

Timetable

	<i>When this is done</i>
1. Determine the H-point of the driver's seat	Before test day
2. Determine the H-point of the passenger's seat	Before test day
3. Dummy installation	Before test day
4. Dummy placement	Test day
5. Dummy positioning	Test day
6. Dummy positioning measurements	Test day - after vehicle has been positioned for test

7.1 Determine the H-point of the driver's seat

The device to be used is the H-point machine as described in SAE J826

If the seat is new and has never been sat upon, a person of mass 75 ± 10 kg should sit on the seat for 1 minute twice to flex the cushions

The seat shall have been at room temperature and not been loaded for at least 1 hour previous to any installation of the machine.

7.1.1 Set the seat back so that the torso of the dummy is as close as possible to the manufacturer's reasonable recommendations for normal use. In absence of such recommendations, an angle of 25 degrees towards the rear from vertical will be used.

7.1.1.1 The driver and passenger seatback angle and seat base shall be set to the same position.

7.1.1.2 Where one seat is height adjustable and the other is fixed, the relative angle between the seat back and the ground should be the same for both seats.

7.1.1.3 Where both seats are adjustable, the manufacturer is asked to supply recommended settings. These should not differ from the nominal settings by more than a reasonable amount. In any of the above situations, the manufacturer may provide convincing information that the seat adjustments should be different from that specified here. If so the fully supported request to vary the set up should be made to the Secretariat.

7.1.2 Place a piece of muslin cloth on the seat. Tuck the edge of the cloth into the seat pan/back join, but allow plenty of slack.

7.1.3 Place the seat and back assembly of the H-point machine on the seat at the centre line of the seat.

7.1.4 Set the thigh and lower leg segment lengths to 401 and 414mm respectively.

7.1.5 Attach lower legs to machine, ensuring that the transverse member of the T-bar is

- parallel to the ground.
- 7.1.6 Place right foot on undepressed accelerator pedal, with the heel as far forwards as allowable. The distance from the centre line of the machine should be noted.
 - 7.1.7 Place left foot at equal distance from centre line of machine as the right leg is from centre line. Place foot flat on footwell.
 - 7.1.8 Apply lower leg and thigh weights.
 - 7.1.9 Tilt the back pan forwards to the end stop and draw the machine away from the seat-back.
 - 7.1.10 Allow the machine to slide back until it is stopped by contacting the seat back.
 - 7.1.11 Apply a 10kg load twice to the back and pan assembly positioned at the intersection of the hip angle intersection to a point just above the thigh bar housing.
 - 7.1.12 Return the machine back to the seat back.
 - 7.1.13 Install the right and left buttock weights.
 - 7.1.14 Apply the torso weights alternately left and right.
 - 7.1.15 Tilt the machine back forwards to the end stop and rock the pan by 5 degrees either side of the vertical. The feet are NOT to be restrained during the rocking. After rocking the T-bar should be parallel to the ground.
 - 7.1.16 Reposition the feet by lifting the leg and then lowering the leg so that the heel contacts the floor and the sole lies on the undepressed accelerator pedal.
 - 7.1.17 Return the machine back to the seat back.
 - 7.1.18 Check the lateral spirit level and if necessary apply a lateral force to the top of the machine back, sufficient to level the seat pan of the machine.
 - 7.1.19 Adjust the seat back angle to the angle determined in 7.1.1, measured using the spirit level and torso angle gauge of the H-point machine. Ensure that the torso remains in contact with the seat back at all times. Ensure that the machine pan remains level at all times.
 - 7.1.20 Measure and record in the test details the position of the H-point relative to some easily identifiable part of the vehicle structure

7.2 Determine the H-point of the Passenger's Seat

Follow the procedure for the determination of the driver's H-point ensuring that the distance from the centre line to the legs is the same as that used in the determination of the driver's H-point.

For both right and left feet, place the feet flat on the floor.

7.3 Dummy Installation

It is the intention that the dummy should not be left to sit directly on the seat for more than 2 hours prior to the test. It is acceptable for the dummy to be left in the vehicle for a longer period, provided that the dummy is not left in overnight or for a similarly lengthy period.

If it is known that the dummy will be in the vehicle for a time longer than 2 hours, then the dummy should be sat on plywood boards placed over the seat. This should eliminate unrealistic compression of the seat.

7.4 Dummy Placement

If the vehicle has only two side doors, it may be necessary to fit the child restraint systems and child dummies (section 7.6) before setting up the Hybrid-III dummies in the front seats.

7.4.1 Ensure that the seat is in the correct position as defined by Section 6.1.

7.4.2 Place the dummy in the seat with the torso against the seat back, the upper arms against the seat back and the lower arms and hands against the outside of the upper leg.

7.5 Dummy Positioning

Dummy positioning should be carried out immediately before the test and the vehicle should not be moved or shaken thereafter until the test has begun. If a test run is aborted and the vehicle brought to a standstill using an emergency braking method, the dummy placement procedure should be repeated. If the dummy, after three attempts cannot be positioned within the tolerances below then it is to be placed as close to the tolerance limits as possible. Record this in the test details.

7.5.1 *H-point*

The dummy's H-point shall be within 13mm in the vertical dimension and 13mm in the horizontal dimension of a point 6mm below the H-point as determined in Section 7.1. Record the position of the dummy H-point in the test details.

7.5.2 *Pelvic Angle*

The pelvic angle measurement gauge should read $22.5^\circ \pm 2.5^\circ$ from the horizontal. Record the measured angle in the test details.

7.5.3 *Head*

The transverse instrumentation platform of the head shall be horizontal to within 2.5° . Levelling of the head shall be carried out in this order:

- Adjust the H-point within the limit (par. 7.5.1)
- Adjust the pelvic angle within the limits (par. 7.5.2)
- Adjust the neck bracket the minimum to ensure that the transverse instrumentation platform is level within limits

Record the measured angle in the test details.

7.5.4 *Arms*

The driver's upper arms shall be adjacent to the torso as far as is possible

The passenger's arms shall be adjacent to the torso and in contact with the seat back.

7.5.5 *Hands*

The driver dummy's hands shall have their palms placed against the steering wheel at a position of a quarter to three. The thumbs should be lightly taped to the wheel.

The passenger's hands should be placed with the palms in contact with the outside of the legs and the little finger in contact with the seat cushion.

7.5.6 *Torso*

The dummies' backs should be in contact with the seat back and the centre line of the dummies should be lined up with the centre line of their respective seats.

7.5.7 *Legs*

The upper legs of both dummies shall be in contact with the seat cushion as far as possible. The distance apart of the outside metal surfaces of the knees of each dummy shall be $270\text{mm} \pm 10\text{mm}$ (except if the left foot is placed on a footrest in par. 7.5.8 below). The legs of the dummies should be in vertical longitudinal planes as far as is possible.

7.5.8 *Feet*

The driver dummy's right foot shall rest on the undepressed accelerator pedal with the heel on the floor. If the foot cannot be placed on the pedal then it should be placed as far forwards as possible with the foot perpendicular to the lower tibia, in line with the centre line of the pedal. The left foot should be placed as flat as possible on the toe-board parallel to the centre line of the vehicle. If any part of the left foot is in contact with a foot-rest or wheel arch when in this position then place the foot fully on this rest providing a normal seating position can still be achieved. Keep the legs in the same vertical longitudinal plane. The knee gap requirement of $270\text{mm} \pm 10\text{mm}$ may be ignored in this case. Note the knee gap in the test details.

The passenger dummy's feet shall be placed with the heel as far forwards as possible and the feet as flat as possible. Both feet shall be parallel to the centre line of the vehicle.

7.5.9 *Seat belt*

7.5.9.1 Where possible, initially position the upper seat belt anchorage in the manufacturers 50th percentile design position. If no design position is provided, set the adjustable upper seat belt anchorage to the mid-position or nearest notch upward.

7.5.9.2 Carefully place the seat belt across the dummy and lock as normal. It will be necessary to re-position the hands as described in Section 7.5.5.

7.5.9.3 Remove the slack from the lap section of the webbing until it is resting gently around the pelvis of the dummy. Only minimal force should be applied to the webbing when removing the slack. The route of the lap belt should be as natural as possible.

7.5.9.4 Place one finger behind the diagonal section of the webbing at the height of the dummy sternum. Pull the webbing away from the chest horizontally forward and allow it to retract in the direction of the D-loop using only the force provided by the retractor mechanism. Repeat this step three times, only.

7.5.9.5 After following the above steps, the seatbelt should lie in a natural position across the dummy sternum assembly and shoulder clavicle. Where this is not the case, for example the belt is close to or in contact with the neck shield or the belt is above the shoulder rotation adjustment screw, and the upper belt anchorage is adjustable the anchorage should be lowered and steps 7.5.9.3 and 7.5.9.4 repeated.

7.5.9.6 The upper anchorage should be lowered by a sufficient amount to ensure a natural belt position following the repetition of steps 7.5.9.3 and 7.5.9.4 repeated. This may require multiple attempts.

7.5.9.7 Once the belt is positioned the location of the belt should be marked across the dummy chest to ensure that no further adjustments are made. Mark also the belt at the level of the D-loop to be sure that the initial tension is maintained during test preparation.

7.5.9.8 Measure the vertical distance between the dummy nose and the diagonal webbing.

7.5.9.9 Measure the horizontal distance between the diagonal webbing and the door/window.

- 7.5.9.10 Where the fitment of the shoulder belt loadcell (Section 4.2.5) significantly influences the natural position of the belt, the loadcell may be supported from above with the use of a weak non metallic wire or thread.

7.6 Child Restraint System (CRS) Installation and Child Dummy Placement

Two CRS's are to be fitted in the rear seat, one suitable for a 3 year old child, the other for an 18 month old infant. Each will be the system recommended by the manufacturer for that size of child. The type of system to be fitted will be determined from the manufacturer. There must be sufficient space between the vehicle interior and CRS to allow for proper installation of the restraint without the need for excessive force. The restraint must not be prevented from sitting in its 'normal' orientation, for example the vehicle interior trim must not cause any obstruction. The dummies must also be allowed to rest in a 'normal' position.

- 7.6.1 Read the relevant sections of the vehicle handbook and the instructions provided with the child restraint. This is to identify any special features of either the vehicle or the child restraint that are intended to improve performance or may influence installation. Instructions on tightening of the adult seat belt around the child restraint should be noted, but the installation itself should follow the procedure below.
- 7.6.2 Calibrate the seat belt tension load cells to be used in the CRS installation process at the required load reading i.e. 50N for lap and diagonal installations and 75N for lap belt applications directly before beginning the installation procedure.
- 7.6.3 Ensure that the seat and belt anchorage positions are as defined in section 6.4. In the case of an adult seat belt that is capable of being switched from an emergency locking retractor (ELR) to an automatic locking retractor (ALR) follow clear advice, obvious to the user, about how the ALR feature should be used on any labels associated with the seat belt (information given in the handbook will be ignored as reading of the handbook cannot be assumed for all users).

7.6.4 *For Integral Harness Systems*

7.6.4.1 Install the child restraint and place the dummy within it. Place the 2.5cm thick and 6cm wide flexible spacer between the back of the manikin and the back of the child restraint. The lower end of the spacer should be at the height of the manikin's hip joint. Adjust the harness restraining the child in accordance with the manufacturer's instructions, but to a tension of 250 +/-50N above the frictional adjuster force. The angle of pull on the webbing should be as indicated in the fitting instructions.

7.6.4.2 Release the harness buckle, remove the spacer, refasten the harness and push the dummy towards the seat back. Arrange the slack within the integral harness so that it is evenly distributed. Make sure the dummy head is upright, and the legs are parallel. Raise the dummy feet and allow them to fall lightly into a stable resting position. Place the dummy's hands so that they are resting on the top of the thighs and tape them lightly in position using a weak paper tape.

7.6.4.3 In the case of a rearward facing restraint, use weak paper tape to locate the dummy head relative to the back of the child restraint. The intention is to prevent dummy displacement under acceleration during the vehicle run-up to the barrier. The tape should be weak enough to break on impact of the vehicle with the barrier.

7.6.5 *For Integral Harness Systems Installed With a 3 Point Seat Belt, With No Lock Off or Lock Off Design That Can Be Released To Give No Friction During Installation*

7.6.5.1 Engage the adult seat belt buckle, fit one load cell outboard on the lap section of the adult belt and one on the free webbing of the diagonal section between the child restraint and the pillar loop. Establish a tension of 50N +/-5N in both the lap and diagonal sections of the adult belt webbing. Apply lock-off devices if available. If the design of the CRS is such that tension is maintained within the lap and diagonal sections of webbing, remove the load cell on the free section of diagonal webbing. However, if removal of the diagonal belt load cell changes the installation tension of the belt, leave the load cell in place. Disconnect any electrical leads and stow them ready for impact.

7.6.5.2 Draw all remaining webbing off the inertia reel of the adult seat belt and allow it to retract slowly under the influence of its own retraction mechanism. Where an ALR system is fitted this action may result in it being activated. If it is the intention for the system not to be activated for the test then draw all the webbing from the reel and allow it to fully retract, prior to the installation of the child seats. Do not fully draw the webbing from the reel after this procedure has been completed.

7.6.6 *For Integral Harness Systems Installed With a 3 Point Seat Belt, With a Lock-Off Design That Cannot Be Released To Give No Friction During Installation.*

7.6.6.1 Place the diagonal belt load cell between the lock-off and the buckle tongue slot and leave it in position during the test. All other aspects of the installation are as per 7.6.5.

7.6.7 *For Booster Seats In Which The Adult Belt Restrains The Child And In Which There Is A Fixed Position Lock-Off.*

7.6.7.1 Place the dummy in the seat with the spacer in position. Locate the diagonal load cell between the lock-off and the buckle tongue slot, in a position where it will not interfere with the dummy's arm movement. Locate the lap section load cell on the outboard adult belt webbing. Establish a load of 50N +/-5N in both sections of the webbing. Leave the load cells in position if their removal would alter the set-up tensions. Release the buckle, remove the spacer and refasten the buckle. Set the dummy back in position as described above in section 7.6.4 and check the webbing spooled on the inertia reel of the adult belt as per section 7.6.5.2.

7.6.8 *For Booster Seats In Which The Position Of The Lock-Off/Shoulder Belt Guide Is Adjustable.*

7.6.8.1 Optimise the position of the lock-off/shoulder belt guide before beginning the installation process. For those systems in which the adult belt is used to restrain the child directly, insert the spacer and continue the installation as described in 7.6.7. If the adult belt is used to restrain the child restraint rather than the child itself install the load cells as described above. After installation to the specified tensions operate any device that is specifically designed to increase adult seat belt tension by use of a lever or cam type system or their equivalent. The intention is to correctly credit special design features aimed at achieving improved installation.

7.6.9 *For Child Restraints Using An Impact Shield To Restrain The Child.*

7.6.9.1 Install the dummy with the spacer and position the shield. Put load cells on lap and diagonal sections of the seat belt. Establish a load of 50N +/-5N in both sections of the webbing and, whilst manually clamping the webbing at the belt guides on the impact shield, release the buckle and rotate the shield forward on the buckle side the minimum amount necessary to allow removal of the spacer. Refasten the buckle, check that the shield is positioned centrally, push the dummy back into the seat and continue with remaining aspects of dummy positioning procedure described in sections 7.6.4.2 and 7.6.5.2. It will probably be necessary to rest the dummy arms on the shield rather than the thighs as has been suggested for other restraint types.

7.6.9.2 For seats installed with a static lap belt use one load cell on the non-buckle side of the adult belt and establish a tension of 75N +/-5N equalised throughout the lap belt. Leave the load cell in place if its removal would alter the set-up tension.

7.6.9.3 The time between child seat installation and impact should be subject to the same limits that are applied to adult dummies and should be kept as short as possible.

7.6.9.4 Retro-reflective marking should be applied to the dummy head in positions likely to help assess dummy head movement at full excursion on the high speed films.

7.6.10 *For "ISOFIX" type seats*

The installation protocol for these seats is under development. If any manufacturers request the use of this type of seat the Euro NCAP Secretariat must be contacted for installation instructions. Where a tensioning/ratchet device is provided to secure the child restraint against the rear seats and/or floor etc, a force not exceeding 100N shall be applied in the direction of the tensioning system's movement. Where a top tether is present it should be attached to the anchorage, a maximum force of $50\text{N} \pm 5\text{N}$ should be applied to the webbing from a position where the user would be expected to install the tether. The angle of pull on the webbing should be as indicated in the fitting instructions. Note: the 50N load is applied directly to the free end of the tether, and intentionally does not take account of the internal frictional characteristics of the adjuster.

7.6.11 *For reclining child restraint systems*

To set the seat angle firstly check the seat itself and instruction manual for recommendations accompanying the seat. If no information is provided consult the manufacturer. If the manufacturer makes no recommendation set to its mid position.

PLEASE NOTE: ALL PASSENGER COMPARTMENT SETTINGS MUST BE THE SAME FOR FRONTAL AND SIDE IMPACTS WITH THE EXCEPTION OF SEAT HEIGHT, GLAZING AND HEAD RESTRAINT HEIGHT

7.7 Dummy Measurements

The following measurements are to be recorded prior to the test after the dummy settling and positioning procedures have been carried out.

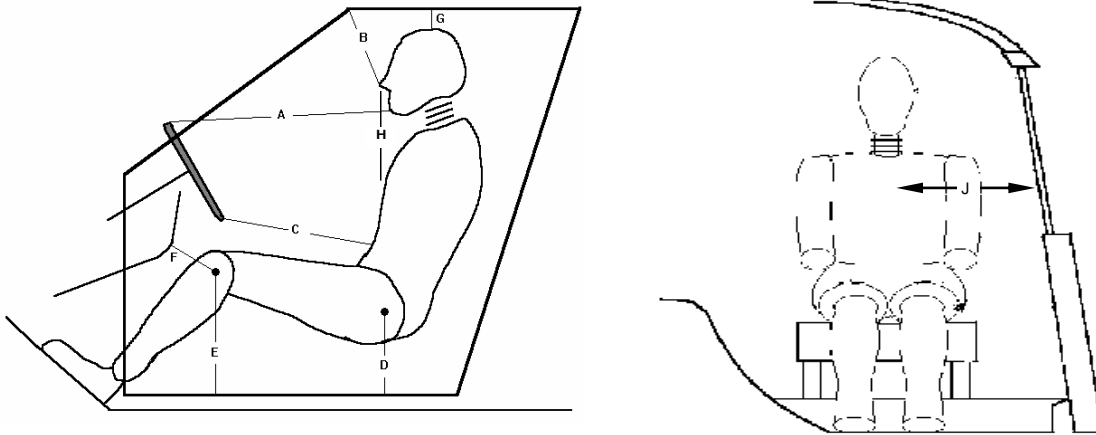

Driver's Side		Passenger's Side	
A	Chin to top of rim	A	Chin to facia
B	Nose to top edge of glass	B	Nose to top edge of glass
C	Stomach to rim	C	Stomach to facia*
D	H-point to top of sill	D	H-point to top of sill
E	Knee bolt to top edge of sill	E	Knee bolt to top edge of sill
F	Knee bolt to top edge of bolster	F	Knee bolt to top edge of bolster*
G	Head to roof surface	G	Head to roof surface
H	Nose to webbing (vertically)	H	Nose to webbing (vertically)
J	Belt webbing to door (horizontally)	J	Belt webbing to door (horizontally)
θ	Neck Angle	θ	Neck Angle
	H-Point Co-ordinates (to vehicle)		H-Point Co-ordinates (to vehicle)
α	Seat back angle (as defined by torso angle)	α	Seat back angle (as defined by torso angle)

8 STILL PHOTOGRAPHY

The following photographs will be taken pre and post-test unless otherwise indicated. Pre-test photographs will be taken with the dummies in their final positions. Examples of the photographs required are given in Annex 1 (Euro NCAP Frontal Impact Photograph Specification Version 1).

<u>No.</u>	<u>View</u>
1	Front view of barrier.
2	Side view of barrier.
3	Side view of barrier at 45 degrees to front.
4	Side view of barrier with vehicle.
5	Car RHS, with camera centred on junction of B-post waist, showing full car.
6	Car RHS, with camera centred on B-post waist, showing rear passenger compartment.
7	Car RHS, with camera aimed at waist height, showing driver's compartment.
8	Car RHS at 45 degrees to front.
9	Front view of car.
10	Car LHS at 45 degrees to front.
11	Car LHS, with camera aimed at waist height, showing front passenger's compartment.
12	Car LHS, with camera centred on B-post waist, showing rear passenger compartment.
13	Car LHS, with camera centred on B-post waist, showing full car.
14	Driver and seat to show driver compartment and position of seat relative to the sill.
15	To show area immediately in front of driver.
16	To show driver's footwell area and location of dummy's feet and pedals.
17	Passenger and seat to show compartment and position of seat relative to sill.
18	To show area immediately in front of passenger.
19	To show passenger footwell area and dummy's feet.
20	To show both child dummies and restraints through LHS rear door.
21	To show both child dummies and restraints through RHS rear door.
22	*Overall view of where the car has come to rest after impact (including barrier).
23	*To show position of all door latches and/or open doors.
24	*To show driver knee contacts with facia (airbag should be lifted if obscuring view).
25	*To show passenger knee contacts with facia (airbag should be lifted if obscuring view).
26	^RHS rear seat belt anchorage with child restraint and P3 dummy in place.
27	^LHS rear seat belt anchorage with child restraint and P1 ½ dummy in place.
28	*P3 dummy and restraint through RHS rear door.
29	*P1 ½ dummy and restraint through LHS rear door.

* Post-test only, ^ Pre-test only

After Dummy Removal

<u>No.</u>	<u>View</u>
30	Passenger compartment from rear window.
31	LHS interior from RHS of car.
32	RHS interior from LHS of car.
33	LHS front door area.
34	RHS front door area.
35	Facia.
36	Passenger footwell.
37	Driver footwell.
38	Steering wheel taken perpendicular to driver's side.
39	Driver right knee impact point.
40	Driver left knee impact point.
41	Passenger knee impact area.

Note: The above photos are for a RHD car, for a LHD car camera locations will switch sides.

9 TEST PARAMETERS

An on-board data acquisition unit will be used. This equipment will be triggered by a contact plate at the point of first contact ($t=0$) and will record digital information at a sample rate of 20kHz (alternatively a sample rate of 10kHz may be used). The equipment conforms to SAE J211.

BEFORE THE TEST, ENSURE THAT THE LIVE BATTERY IS CONNECTED, A SINGLE KEY IS IN THE IGNITION, THE IGNITION IS ON AND THAT THE AIRBAG LIGHT ON THE DASHBOARD ILLUMINATES AS NORMAL (WHERE FITTED)

If the vehicle is fitted with a brake pedal retraction mechanism which requires a vacuum present in the brake system, the engine may be ran for a predetermined time, specified by the manufacturer.

9.1 Deformable Barrier

Fix a deformable barrier to the concrete block. The height of this barrier should be 200mm \pm 5mm from the ground. A full description of the barrier and how it is to be fitted is given in Appendix 1.

9.2 Speed

9.2.1 Measure the speed of the vehicle as near as possible to the point of impact.

9.2.2 This speed should be 64km/h (40mph) \pm 1km/h. Record the actual test speed in the test details.

TARGET SPEED = 64km/h \pm 1km/h

9.3 Overlap

9.3.1 With the vehicle offered up against the barrier, tape a small pin as near as possible to that edge of the deformable barrier which is to be struck.

9.3.2 Mark the point on the bumper of the vehicle where the pin should strike if an exact overlap of 40% was achieved.

9.3.3 After the test, if the mark made by the pin is not within the tolerance rectangle described below, film analysis will be used to try to assess the overlap. Both the horizontal and vertical alignments shall be noted in the test report.

TARGET OVERLAP = 40% \pm 20mm

TARGET VERTICAL ALIGNMENT = \pm 25mm

After Test

9.4 Door Opening Force

- 9.4.1 Check that none of the doors have locked during the test
- 9.4.2 Try to open each of the doors (front doors followed by rear doors) using a spring-pull attached to the external handle. The opening force should be applied perpendicular to the door, in a horizontal plane, unless this is not possible. The manufacturer may specify a reasonable variation in the angle of the applied force. Gradually increase the force on the spring-pull, up to a maximum of 500N, until the door unlatches. If the door does not open record this then try to unlatch the door using the internal handle. Again attempt to open the door using the spring-pull attached to the external handle. Record the forces required to unlatch the door and to open it to 45° in the test details.
- 9.4.3 If a door does not open with a force of 500N then try the adjacent door on the same side of the vehicle. If this door then opens normally, retry the first door.
- 9.4.4 If the door still does not open, record in the test details whether the door could be opened using extreme hand force or if tools were needed.

Note: In the event that sliding doors are fitted, the force required to open the door sufficiently enough for an adult to escape should be recorded in place of the 45° opening force.

9.5 Dummy Removal

- 9.5.1 Do not move the driver or passenger seats. Try to remove the dummies.
- 9.5.2 If the dummies cannot be removed with the seats in their original positions, recline the seat back and try again. Note any entrapment of the dummy.
- 9.5.3 If the dummies can still not be removed, try to slide the seats back on their runners.
- 9.5.4 If the dummies can still not be moved, the seats can be cut out of the car.
- 9.5.5 Record the method used to remove the dummies.

9.6 Intrusion Measurements

Take the vehicle intrusion measurements. See Section 2.2 for a full description of how to do this.

Where a specified requirement has not been met, Euro NCAP reserves the right to decide whether or not the test will be considered as valid.

10 CALCULATION OF INJURY PARAMETERS

The following table lists all of the channels which are to be measured and the Channel Frequency Class at which they are to be filtered. Traces should be plotted of all of these channels. The injury calculation column lists the parameters which will be calculated for each location. If the injury parameter is not a simple peak value and involves some further calculation, details are given subsequently. Peak levels of head or neck parameters occurring from impacts after the dummy head rebounds from an initial contact are not considered when calculating maximum levels of injury parameters. Ringing or other anomalous spikes in the data traces should be removed and peak values/HIC calculated without consideration of the anomaly. A copy of both the original and unmodified traces must always be provided in the data.

Location	Parameter	CFC ³	Injury Calculation
Head	Accelerations, $A_x A_y A_z$	1000	Peak Resultant acceleration HIC ₃₆ Resultant 3msec exceedence
Neck	Forces, $F_x F_y F_z$	1000	Tension ($+F_z$) continuous exceedence Shear (F_x) continuous exceedence
	Moments, $M_x M_y M_z$	600	Peak Extension (M_y)I
Chest	Accelerations, $A_x A_y A_z$	180	Peak resultant acceleration Resultant 3 msec exceedence
	Deflection, D	180	Peak deflection Viscous Criterion
Femurs (L & R)	Forces, F_z	600	Compressive Axial Force ($-F_z$) Continuous exceedence
Knees (L & R)	Displacements, D	180	Peak displacement
Upper Tibia (L & R)	Forces, $F_x F_z$	600	Peak Tibia Compression ($-F_z$) Tibia Index
	Moments, $M_x M_y$	600	
Lower Tibia (L & R)	Forces, $F_x F_z$	600	Peak Tibia Compression ($-F_z$) Tibia Index
	Moments, $M_x M_y$	600	

³ All CFCs taken from SAE J211

TNO P3

Location	Parameter	CFC ³	Injury Calculation
Head	Accelerations, A _x A _y A _z	1000	Peak Resultant acceleration Resultant (+ve) 3msec exceedence
Chest	Accelerations, A _x A _y A _z	180	Peak resultant acceleration Resultant (+ve) 3msec exceedence

TNO P1½

Location	Parameter	CFC ³	Injury Calculation
Head	Accelerations, A _x A _y A _z	1000	Peak Resultant acceleration Resultant (+ve) 3msec exceedence Vertical (+ve & -ve) 3msec exceedence
Neck	Forces, F _x F _y F _z	1000	
Chest	Accelerations, A _x A _y A _z	180	Peak resultant acceleration Resultant (+ve) 3msec exceedence Vertical (+ve & -ve) 3msec exceedence

Using the above channels, dummy injury parameters can be calculated according to the following procedures:

10.1 Head

10.1.1 Calculate the resultant head acceleration A_R from the three components A_x, A_y and A_z after they have been filtered and determine the maximum value of A_R

$$A_R = \sqrt{A_x^2 + A_y^2 + A_z^2}$$

10.1.2 Determine the highest value of the resultant head acceleration

10.1.3 Calculate the Head Injury Criterion (HIC) according to

$$HIC = (t_2 - t_1) \left[\frac{\int_{t_1}^{t_2} A_R \cdot dt}{(t_2 - t_1)} \right]^{2.5}$$

where A_R is expressed in multiples of g. Maximise HIC for any time 'window' (t₂ -

t₁) up to 36 milliseconds.

- 10.1.4 Determine the acceleration level which A_R exceeds for a cumulative time period of three milliseconds i.e. the head 3msec exceedence.

10.2 Neck

- 10.2.1 Calculate the neck extension bending moment from

$$(M_y)_i = M_y - f_x \cdot d$$

Where M_y and F_x are bending moment and shear force respectively measured at the transducer and d is the distance from the transducer to the interface (d=0.01778).

See (SAEJ1733).

- 10.2.2 Determine the 'continuous exceedence' of both the neck tension (F_z positive) and neck shear (F_x) forces.

10.3 Chest

- 10.3.1 Determine the greatest value of the chest deflection D_{chest}

- 10.3.2 Calculate the Viscous Criterion according to the equation

$$\text{Viscous Criterion} = 1.3 V_{(t)} \times C_{(t)}$$

D_(t) is the instantaneous chest deflection at any time t. C_(t) is the compression, related to the chest deflection D_(t)

$$C_{(t)} = \frac{D_{(t)}}{0.229}$$

V is the velocity of deflection and is calculated as the differential of the deflection with respect to time:

$$V_{(t)} = \frac{8 * [D_{(t+1)} - D_{(t-1)}] - [D_{(t+2)} - D_{(t-2)}]}{12 \delta t}$$

where δt is the time interval between successive digital samples of D_(t). Calculate V_(t)*C_(t) continuously with time and determine its greatest value.

10.4 Femurs

- 10.4.1 For each of the femurs, calculate the continuous exceedence in compression (F_z negative)

10.5 Knees

- 10.5.1 For each of the knees, determine the greatest value of the knee displacement D

10.6 Tibia

- 10.6.1 At the upper and lower of both the left and the right tibias, calculate the resultant bending moment M_R from M_x and M_y after they have been filtered.

$$M_{R(t)} = \sqrt{M_{X(t)}^2 + M_{Y(t)}^2}$$

- 10.6.2 Calculate the Tibia Index (TI) at the upper and lower tibia of each leg according to the equation

$$TI_{(t)} = \left| \frac{M_{R(t)}}{(M_R)_C} \right| + \left| \frac{F_{Z(t)}}{(F_Z)_C} \right|$$

$TI_{(t)}$ is the instantaneous value of the Tibia Index at time t. $(M_R)_C$ is the critical value of the bending moment = 225Nm and $(F_Z)_C$ is the critical value of the axial force = 35.9kN

The vertical lines indicate that the modulus should be taken.

- 10.6.3 Determine the highest value of the Tibia Index.
10.6.4 Determine the highest value of the axial compressive force measured at either the upper or lower tibia.

10.7 Child Dummies

- 10.7.1 For the P3 and P1½ dummies, calculate the resultant head and chest acceleration A_R from the three components A_x , A_y and A_z after they have been filtered and determine the maximum value of A_R

$$A_R = \sqrt{A_x^2 + A_y^2 + A_z^2}$$

- 10.7.2 For the P3 and P1½ dummies, determine the level which head and chest resultant accelerations (+ A_R) exceed for a cumulative time of three milliseconds.
10.7.3 For the P3 and P1½ dummies, determine the level which chest vertical accelerations (+ve & -ve A_z) exceed for a cumulative time of three milliseconds.
10.7.4 For the P1½ dummy seated rearward facing, determine the level which head vertical accelerations (+ve & -ve A_z) exceed for a cumulative time of three milliseconds.

Appendix I

Frontal Impact Barrier Specification

BARRIER SPECIFICATION

The frontal impact barrier for testing and its mounting to the block shall conform to the following specification:

1 Component and Material Specifications

The dimensions of the barrier are illustrated in Figure 1. The dimensions of the individual components of the barrier are listed separately below.

Main Honeycomb Block

Dimensions

Height:	650mm [in direction of honeycomb ribbon (foil) axis]
Width:	1000mm
Depth:	450mm [in direction of honeycomb cell axes]
	All above dimensions ± 2.5 mm
Material:	Aluminium 3003 (BS 1470)
Foil Thickness:	0.076mm $\pm 15\%$
Cell Size:	19.1mm $\pm 20\%$
Density:	28.6kg/m ³ $\pm 20\%$
Crush Strength:	0.342MPa +0% -10%
	[in accordance with test method described in Section 2]

Bumper Element

Dimensions

Height:	330mm [in direction of honeycomb ribbon axis]
Width:	1000mm
Depth:	90mm [in direction of honeycomb cell axes]
	All above dimensions ± 2.5 mm
Material:	Aluminium 3003 (BS 1470)
Foil Thickness:	0.076mm $\pm 15\%$
Cell Size:	6.4mm $\pm 20\%$
Density:	82.6kg/m ³ $\pm 20\%$
Crush Strength:	1.711MPa +0% -10%
	[in accordance with test method described in Section 2]

Backing Sheet

Dimensions

Height:	800mm
Width:	1000mm
	All above dimensions ± 2.5 mm
Thickness:	2.0 ± 0.1 mm
Material:	Aluminium 5251/5052 (BS 1470)

Cladding Sheet

Dimensions

Height:	1700mm
Width:	1000mm
	All above dimensions ± 2.5 mm
Thickness:	0.81 ± 0.07 mm
Material:	Aluminium 5251/5052 (BS 1470)

Bumper Facing Sheet

Dimensions

Height:	330mm
Width:	1000mm
	All above dimensions ± 2.5 mm
Thickness:	0.81 ± 0.07 mm
Material:	Aluminium 5251/5052 (BS 1470)

Adhesive

The adhesive to be used throughout shall be a two-part polyurethane (such as Ciba-Geigy XB5090/1 resin with XB5304 hardener, or equivalent).

2 Aluminium Honeycomb Certification

A complete testing procedure for certification of aluminium honeycomb is given in NHTSA TP-214D-02. The following is a summary of the procedure as it should be applied to 0.342MPa and 1.711MPa material for the frontal impact barrier.

2.1 Sample Locations

To ensure uniformity of crush strength across the whole of the barrier face, 8 samples shall be taken from 4 locations evenly spaced across the honeycomb block. For a block to pass certification, 7 of these 8 samples must meet the crush strength requirements of the following sections.

The location of the samples depends on the size of the honeycomb block. First, four samples, each measuring 300mm×300mm×50mm thick shall be cut from the block of barrier face material. Please refer to Figure 2 for an illustration of how to locate these sections within the honeycomb block. Each of these larger samples shall be cut into samples for certification testing (150mm×150mm×50mm). Certification shall be based on the testing of two samples from each of these four locations. The other two should be made available to the customer, upon request.

2.2 Sample Size

Samples of the following size shall be used for testing:

Length = 150mm ± 6mm

Width = 150mm ± 6mm

Thickness = 50mm ± 2mm

The walls of incomplete cells around the edge of the sample shall be trimmed as follows:

In the 'W' direction, the fringes shall be no greater than 1.8mm (see Figure 3)

In the 'L' direction, half the length of one bonded cell wall (in the ribbon direction) shall be left at either end of the specimen (see Figure 3).

2.3 Area Measurement

The length of the sample shall be measured in three locations, 12.7mm from each end and in the middle, and recorded as L1, L2 and L3 (Figure 3). In the same manner, the width shall be measured and recorded as W1, W2 and W3 (Figure 3). These measurements shall be taken on the centreline of the thickness. The crush area shall then be calculated as:

$$A = \frac{(L1 + L2 + L3)}{3} \times \frac{(W1 + W2 + W3)}{3}$$

2.4 Crush Rate and Distance

The sample shall be crushed at a rate of not less than 5.1mm/min and not more than 7.6mm/min. The minimum crush distance shall be 16.5mm.

2.5 Data Collection

Force versus deflection data are to be collected in either analog or digital form for each sample tested. If analog data are collected then a means of converting this to digital must be available. All digital data must be collected at a rate of no less than 5Hz (5 points per second).

2.6 Crush Strength Determination

Ignore all data prior to 6.4mm of crush and after 16.5mm of crush. Divide the remaining data into three sections or displacement intervals (n=1,2,3) (see Figure 4), where:

n=1	-	6.4mm - 9.7mm inclusive
n=2	-	9.7mm - 13.2mm exclusive
n=3	-	13.2mm - 16.5mm inclusive

For each of these three displacement intervals, calculate the average crush force F(n) using *all* of the points measured within that interval. Thus,

$$F(n) = \frac{[F(n)_1 + F(n)_2 + \dots + F(n)_m]}{m}; n = 1, 2, 3$$

where m is the number of data points in each of the displacement intervals.

Using the area A, measured as described in Section 2.3, calculate the crush strength of each displacement interval as follows:

$$S(n) = \frac{F(n)}{A}; n = 1, 2, 3$$

Thus, for each sample tested, there should be three values of crush strength, each covering one of the displacement intervals detailed above.

2.7 Sample Crush Strength Specification

For a honeycomb sample to pass this certification, the average crush strength of each of the three displacement intervals must meet the following condition:

$$\begin{array}{ll} 0.308\text{MPa} \leq S(n) \leq 0.342\text{MPa} & \text{for } 0.342\text{MPa material} \\ 1.540\text{MPa} \leq S(n) \leq 1.711\text{MPa} & \text{for } 1.711\text{MPa material} \end{array}$$

$$n=1,2,3$$

Note: It is not satisfactory to calculate the crush strength averaged over the entire crush distance (6.4mm - 16.5mm). A sample may give an overall average that satisfies the requirement, while individual displacement intervals may not. The procedure of Section 2.6 must therefore be followed.

2.8 Block Crush Strength Specification

Eight samples are to be tested from four locations, evenly spaced across the block. For a block to pass certification, 7 of the 8 samples must meet the crush strength specification of the previous section.

3 Adhesive Bonding Procedure

Immediately before bonding, Aluminium sheet surfaces to be bonded shall be thoroughly cleaned using a suitable solvent, such as 1,1,1 Trichloroethane. This is to be carried out at least twice or as required to eliminate grease or dirt deposits. The cleaned surfaces shall then be abraded using 120 grit abrasive paper. Metallic/Silicon Carbide abrasive paper is not to be used. The surfaces must be thoroughly abraded and the abrasive paper changed regularly during the process to avoid clogging, which may lead to a polishing effect. Following abrading, the surfaces shall be thoroughly cleaned again, as above. In total, the surfaces shall be solvent cleaned at least four times. All dust and deposits left as a result of the abrading process must be removed, as these will adversely affect bonding.

The adhesive shall be applied to one surface only, using a ribbed rubber roller. In cases where honeycomb is to be bonded to Aluminium sheet, the adhesive should be applied to the Aluminium sheet only. A maximum of 0.5kg/m^2 shall be applied evenly over the surface, giving a maximum film thickness of 0.5mm.

4 Construction

The main honeycomb block shall be adhesively bonded to the backing sheet such that the cell axes are perpendicular to the sheet. The cladding sheet shall be bonded to the front surface of the honeycomb block. The top and bottom surfaces of the cladding sheet shall NOT be bonded to the main honeycomb block but should be positioned closely to it. The cladding sheet shall be adhesively bonded to the backing sheet at the mounting flanges.

The bumper element shall be adhesively bonded to the front of the cladding sheet such that the cell axes are perpendicular to the sheet. The bottom of the bumper element shall be flush with the bottom surface of the cladding sheet. The bumper facing sheet shall be adhesively bonded to the front of the bumper element.

The bumper element shall then be divided into three equal sections by means of two horizontal slots. These slots shall be cut through the entire depth of the bumper section and extend the whole width of the bumper. The slots shall be cut using a saw; their width shall be the width of the blade used and shall not exceed 4.0mm.

Clearance holes for mounting the barrier are to be drilled in the mounting flanges (shown in Figure 5). The holes shall be of 9.5mm diameter. Five holes shall be drilled in the top flange at a distance of 40mm from the top edge of the flange and five in the bottom flange, 40mm from the bottom edge of that flange. The holes shall be at 100mm, 300mm, 500mm, 700mm, 900mm from either edge of the barrier. All holes shall be drilled to ± 1 mm of the nominal distances. These hole locations are a recommendation only. Alternative positions may be used which offer at least the mounting strength and security as that provided by the above mounting specifications.

5 Mounting

The deformable barrier shall be rigidly fixed to the edge of a block of reinforced concrete weighing at least 70 tonnes or to some structure attached thereto. The attachment of the barrier face shall be such that the vehicle shall not come into contact with any structure at any height above 75mm from the top surface of the barrier (excluding the upper flange) during any stage of the impact. The front face of the surface to which the deformable face is attached shall be flat and continuous over the height and width of the face and shall be vertical and perpendicular to the axis of the run-up track. The attachment surface shall not be displaced by more than 10mm during any stage of the test. If necessary, additional anchorage or arresting devices shall be used to prevent displacement of the concrete block. The edge of the deformable barrier shall be aligned with the edge of the attachment surface appropriate for the side of the vehicle to be tested.

The deformable barrier shall be attached by means of ten bolts, five in the top mounting flange and five in the bottom. These bolts shall be of at least 8mm diameter. Steel clamping strips shall be used for both the top and bottom mounting flanges (see Figure 2). These strips shall be 60mm high and 1000mm wide and have a thickness of at least 3mm. The edges of the clamping strips should be rounded off to prevent tearing of the barrier against the strip during impact. The edge of the strip should be located no more than 5mm above the base of the upper barrier mounting flange, or 5mm below the top of the lower barrier mounting flange. Five clearance holes of 9.5mm diameter shall be drilled in both strips to correspond with those in the mounting flange on the barrier (see Section 4). The mounting strip and

barrier flange holes may be widened from 9.5mm up to a maximum of 25mm in order to accommodate differences in back-plate arrangements and/or load cell wall hole configurations. None of the fixtures shall fail in the impact test.

In the case where the deformable barrier is mounted on a load cell wall (LCW) it should be noted that the above dimensional requirements for mountings are intended as a minimum. Where a LCW is present, the mounting strips may be extended to accommodate higher mounting holes for the bolts. If the strips are required to be extended, then thicker gauge steel should be used accordingly, such that the barrier does not pull away from the wall, bend or tear during the impact. If an alternative method of mounting the barrier is used, it should be at least as secure as that specified in the above paragraphs.

If $a < 900\text{mm}$: $x = 1/5(b - 1200)$ and $y = 1/2(a - 300)$ [for ab]

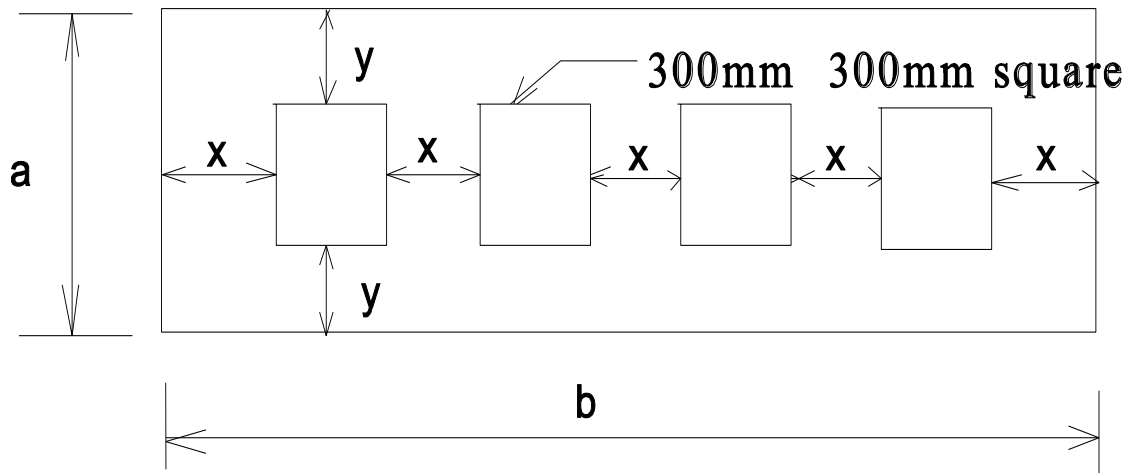

If $a \geq 900\text{mm}$: $x = 1/3(b - 600)$ and $y = 1/3(a - 600)$ [for ab]

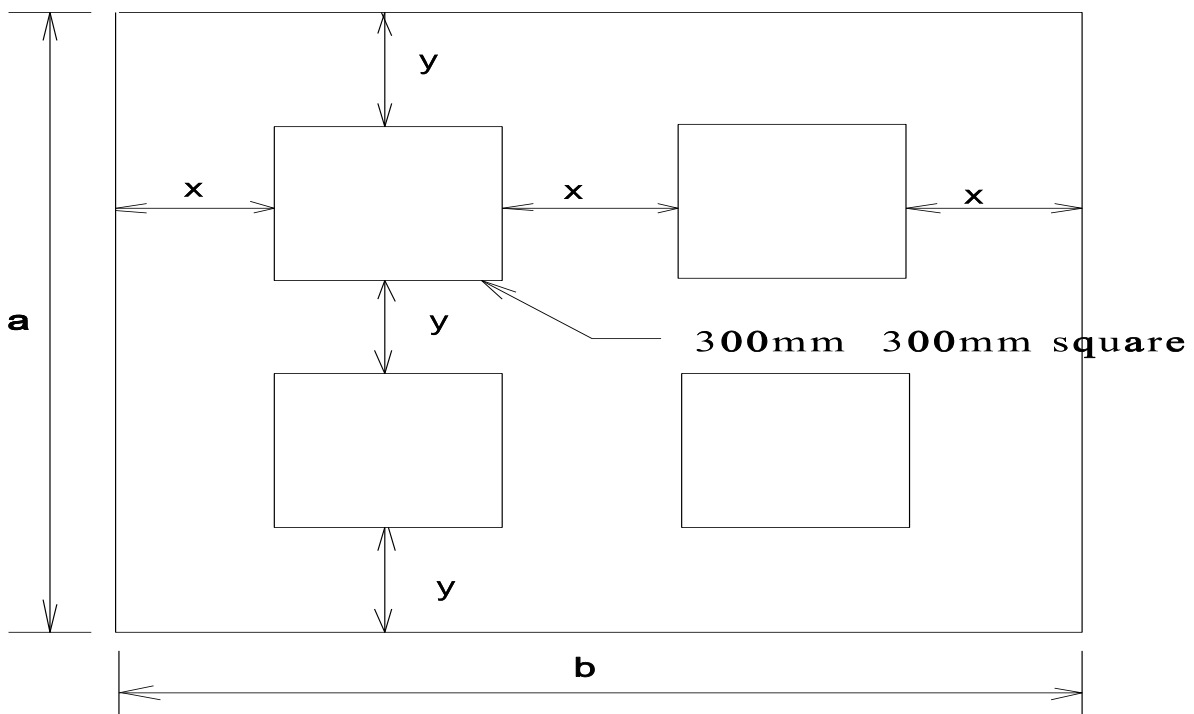

Figure 2 Locations of Samples for Certification

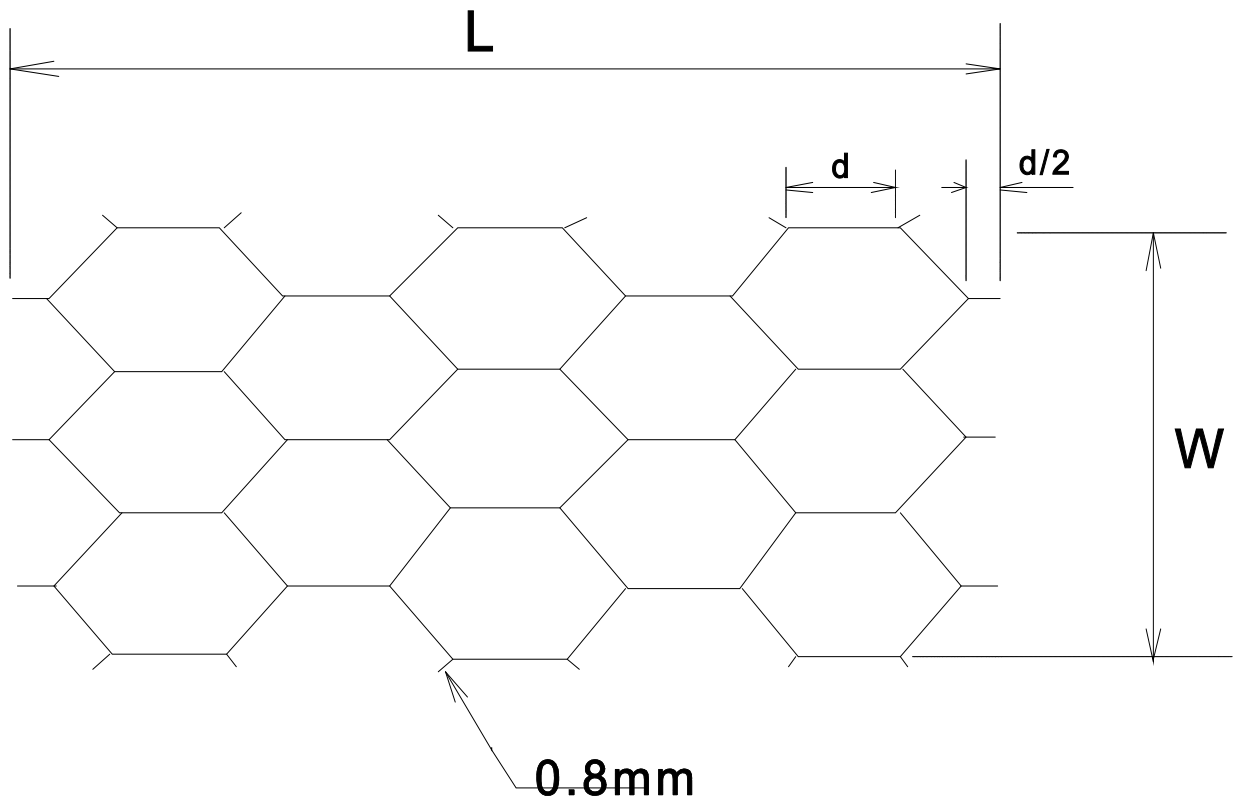
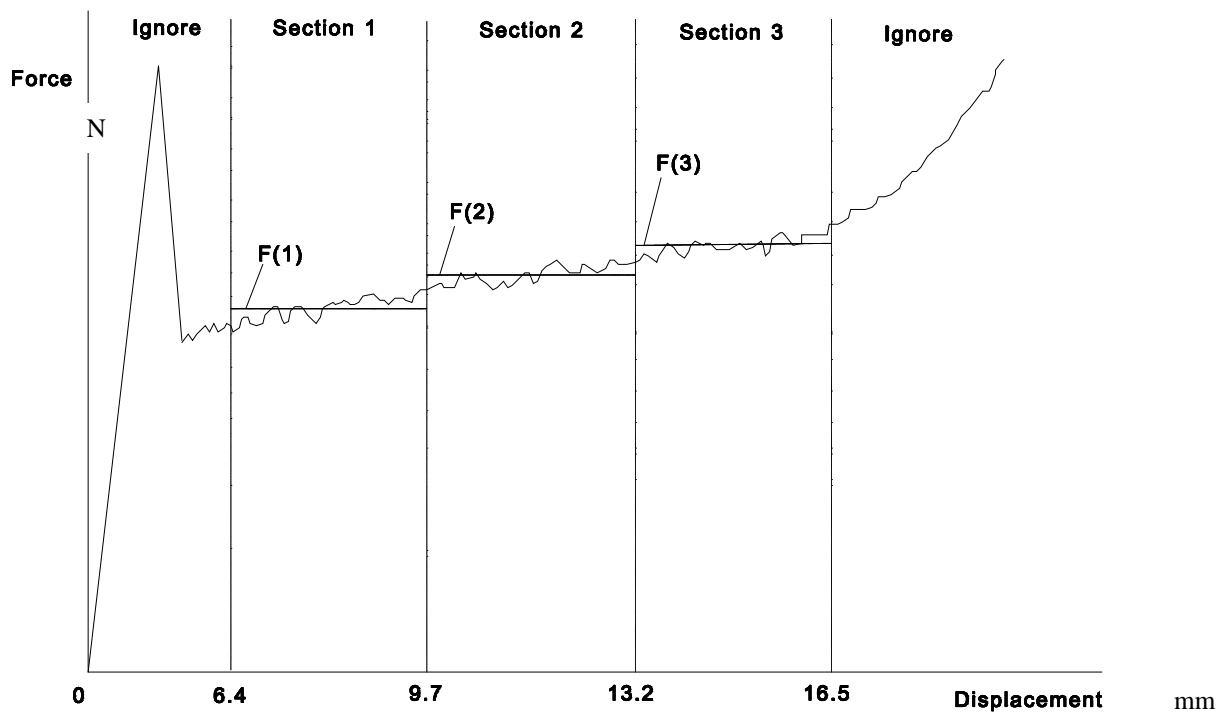
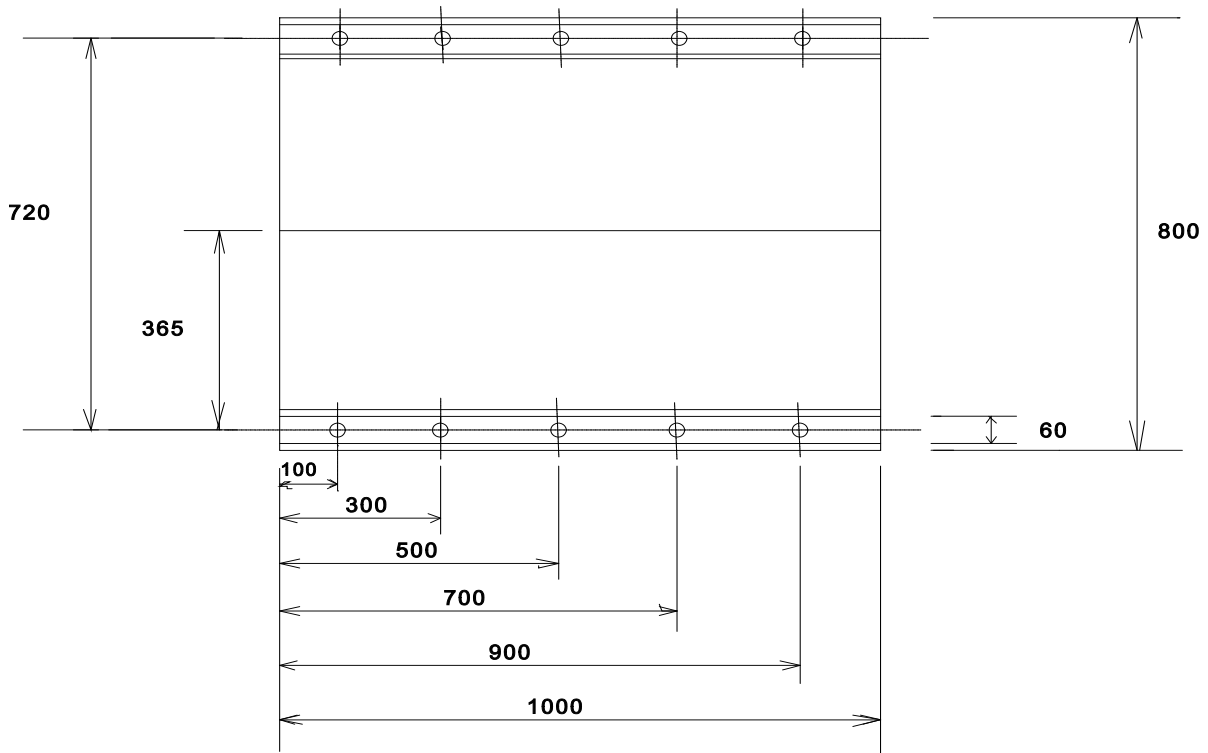

Figure 3 Honeycomb Axes and Measured Dimensions



$$\text{Crush Strength } S(n) = \frac{F(n)}{A}; n = 1, 2, 3$$

Figure 4 Schematic Load-Displacement Trace for Honeycomb Certification



Dimensions in mm
 Hole Diameters = 9.5mm

Figure 5 Recommended Positions of Holes for Barrier Mounting